



The Gull

BULLETIN OF THE CENTRAL ONTARIO GLIDER GROUP



April 2008

2008 Executive

President
Vice President
Secretary
Safety

Bob Sherliker
Roy Bourke
Helmut Berger
Jozef Banial

Treasurer
Field Coordinator
Contest Coordinator
Newsletter

Tony Boothman
Doug Pike
Doug Pike
Roy Bourke

Web Site <http://www.cogg.ca>

The Spring has Sprung!

It sure has been a long winter, hasn't it? We didn't break the record for total snowfall in Toronto...yet. Hopefully this spring we can escape any more of what the French call "merde blanche". But please don't plan on flying at a COGG field until our Field Coordinator, Doug Pike, tells us which field we will be using, and gives the "OK" on its condition.

COGG club dues are due for those who have not yet renewed their membership for 2008. The price is the same as previous years and it is one of the biggest bangs for your buck that you will find anywhere in the modelling world;.....an excellent flying site, newsletters, free barbecue each year, free breakfast at the AGM and, best of all, the camaraderie of modellers that speak the same language as you do.....silent climb-and-glide flight.

The list of current (2008) members is attached at the end of this newsletter. If your name isn't on this list, and you have rejoined, please contact me at (416-493-0111) or rsbourke@3web.net

Otherwise, if you intend to fly with us this year, please get your membership renewal in as soon as possible. And everyone, please make sure you have renewed your membership in MAAC. You can't fly at our club field without it, and we simply can't afford to have an accident at the field by a flier without MAAC insurance. We will be checking for current MAAC membership again this year, both at the field and with MAAC.

At the last COGG Annual General Meeting, a motion was passed regarding display of membership cards.

(From the minutes of the AGM, 28 Oct 2007)

“New Motion.... That all flyers shall attach a copy of their current MAAC and COGG membership cards to their frequency pegs, which must be on display on the frequency board while flying.

.....*Carried “*

So you have plenty of time to gear yourself up with a frequency pin that carries a small plastic tag containing reduced-size copies of your membership cards. It is an easy thing to make, and it will dispel any controversy about your flying at the field with respect to COGG and MAAC memberships.



Also new this year is the requirement for all clubs to display a warning sign about the risk of being near model aircraft flying. (This sign has to be displayed even at Indoor clubs where the models rarely weigh more than an ounce or two). But we haven't any choice! No sign.....no insurance.

Joe Banial has volunteered to make up a pair of mounting plates to display these signs, on the frequency board and another appropriate place.

The Contest Season

Here is the blended line up for contests this year at the COGG and SOGGI fields, and international.

<u>Contest</u>	<u>Dates</u>	<u>Location</u>
2 Meter	Sun 25 May	COGG
Electric F5J *	Sun 01 June	COGG
Bud's Golden Oldies	Sat 14 June	SOGGI
Open Man on Man	Sun 22 June	COGG
Open Sailplane + RES	Sun 06 July	COGG
2 Meter and Club Day	Sun 03 Aug	SOGGI
Hand Launch	Sat 16 Aug	COGG
Open Sailplane	Sun 17 Aug	COGG
Big Bird Bash	Sun 31 Aug	SOGGI
Electric Sport Sailplane*	Sun 07 Sept	COGG
Open Sailplane	Sun 14 Sept	COGG

* The rules for this F5J event are different from what you may be used to. Here they are again:

Airframe – No limit on size or control functions.

Power System – Direct drive motor (of any type) with a published weight of no more than 68 grams.

Battery – 3 or fewer LiPo cells (any capacity)

9 or fewer NiCd or NiMH cells (any capacity)

3 or fewer LiFePO₄ (a.k.a. LiFe, M1, A123, etc.)

Task - Man on Man in a 10-minute round

(Working Time of 10 minutes)

One unlimited continuous motor run

Flight time starts when you stop the motor

Landing in a 15 meter dia. circle yields 30 points

Landing after the 10 min. Working Time ends yields no landing points.

This event is designed for aircraft that can be easily and quickly built, and powered with relatively inexpensive motors and speed controllers.

If the June event is successful and well-attended, the same type of event will be held again in September in place of the 1/2A (Speed 400) portion of the Sport Electric Sailplane events in September.



The Onyx JW and JWS

Last year, a number of COGG members got together and imported a number of F3J class moulded sailplanes in a mass purchase direct from the manufacturer in the Ukraine. Over the past year, these Onyx aircraft have proven to be excellent fliers and very competitive aircraft in the International F3J and unlimited classes of sailplane competitions.

At the US Soaring Nationals last year at Muncie Indiana, Joe Wurts was flying a specially modified version of the Onyx. Joe, as you no doubt know, is quite famous as a sailplane designer and competitor, several times World Champion, designer of the Icon sailplane, and of the sailplane programming software in the JR 9303 transmitter, and a renowned academic in aircraft design. He had commissioned the Impres Company, builders of the Onyx, to build him a modified Onyx using his own airfoils and incorporating other custom modifications.

The Impres Company is now offering Onyx sailplanes with Joe Wurts' modifications in them, calling them the Onyx JW (with Joe's airfoils and a Supra-type tail) and Onyx JWS (the same JW model except with a short Supra-type pylon for the wing).

A few of our members are now planning another bulk purchase of Onyx JW and JWS models, hopefully with similar discounts and other financial savings that we were able to obtain last year with the Onyx bulk purchase. If any of you would like to get in on this new bulk procurement, please contact Joe Banial at 905-567-3925 or jbww@rogers.com

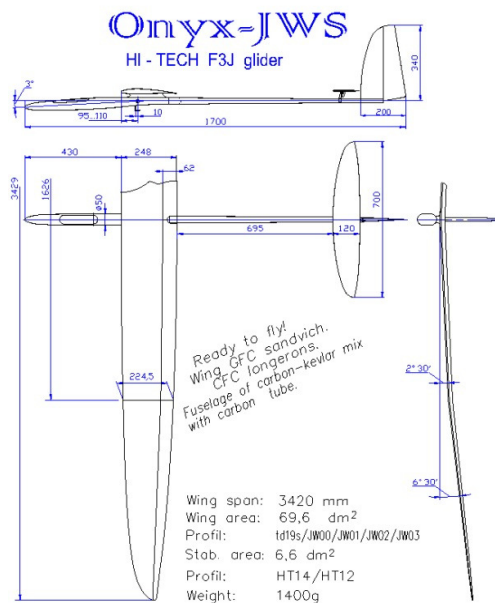

Electric Power for Model Aircraft

Roy Bourke and Michael Rogozinski

The following is a summary of talk given by Robert Pike at the April 2007 EMFSO Winter Workshop, explaining the basic logic and guidelines that have been used successfully by other modellers to determine what kind of electric power system to use in various types of model airplanes.

Volts x Amps = Watts:

This simple equation yields the amount of power (in **Watts**) being delivered to the electrical system, as determined by the electro motive force (or emf measured in **Volts**) applied to, and the resultant electrical current (in **Amps**) drawn by the circuit. If we measure the “Volts” and the “Amps” under load (i.e. while the motor is turning a propeller) the equation yields the total input power being delivered to the drive system under load or in-flight.

Battery Voltage: Each cell of a battery of any specific type (or “chemistry”) produces a characteristic “voltage” which varies somewhat under load, but is usually specified as a nominal Voltage. We normally refer to the “voltage” of a battery pack as being the nominal voltage of each cell in the pack multiplied by the number of cells.

Examples: -

A 3-cell Lithium-polymer battery pack is considered to be an 11.1 Volt pack, since each cell is rated at a nominal 3.7 Volt output.

A 10-cell Nickel Cadmium battery pack is considered to be a 12-Volt pack, since each cell has a nominal rating of 1.2Volts

However, the voltage of a battery can drop under load, so for the purpose of calculating power requirements, we usually use a lower figure than the nominal voltage, figuring about 1.1 or 1.0 Volts per cell for Nicads and NiMHy cells and perhaps 3.2 or 3.3 Volts per cell for LiPoly cells.

Amps:

The current (measured in Amps) is a measure of the rate at which electricity is flowing in the circuit. The amount of current “drawn” by a circuit is determined by how much load is in the circuit (or how much work is being done or heat is being produced). In the case of an electric motor driving a propeller, current draw is affected by how fast the propeller is turning, and the amount of torque the motor must exert to turn it at that speed. If we make the motor work harder by installing a larger diameter propeller or a propeller with higher pitch, the motor will draw more current.

Similarly any component in the circuit that affects the overall load on the circuit, such as the motor itself, speed controller, battery, wires used, etc. will affect the overall current draw. Consequently all components in the electrical circuit must be selected such that they match the power characteristics of the circuit and that the manufacturer’s maximum levels of voltage and current for each piece of equipment are not exceeded. Otherwise components can overheat and become damaged.

Battery Capacity:

The capacity (designated as “C”) of a cell or a battery is a specification of the total amount of electrical energy that the battery can deliver, (or the equivalent of “ the amount of “gas” in the “tank”!!) It is usually specified as the maximum amount of current that the battery can deliver for an hour (expressed as milliamp-hours or mAh). Specifications for a battery pack also include a maximum level of current that can be drawn safely from the pack, usually expressed as a multiple of the capacity C.

Examples:

A 3-cell 1320mAh (or 1.32 A-hours) Lithium-polymer battery pack that is rated at 10C of continuous current can deliver 1.32 Amps for an hour, or can be safely discharged at a rate of 13.2 Amps (but for a shorter period of time, namely 1/10 hour or 6 minutes)

A 6-cell 6000mah Lithium-polymer battery pack that is rated at 20C of continuous current can deliver 6 Amps of current for an hour, or can be safely discharged at a rate of 120 Amps (but only for 1/20 hour or 3 minutes).

Since a higher level of current (Amp draw) will drain a battery pack faster, a higher Amp-hour capacity may be necessary. (Of course, a bigger battery pack weighs more, possibly necessitating more power to fly a heavier model!)

Power:

Power (in Watts) that is calculated by the product of the voltage and current that the power system delivers to the motor and propeller is the input-power. Output-power is the actual power produced by the motor and propeller, but this is difficult to measure without special equipment. Output-power is always less than the input since no motor-propeller combination is 100% efficient. Generally, the more efficient the motor and propeller are, the closer output-power can approach the level of input power.

Examples: -

Considering only the efficiency of the motor, the output power of a cheap Speed 400 can-type motor may produce only about 50% of measured input-power. (The choice of a poorly matched propeller can drop the overall efficiency of the motor-propeller combination significantly lower.)

Actual output power of a well-built brushless motor may produce close to 90% of calculated input power. Again the choice of an efficient well-matched propeller is important.

Application of input power (or “wattage”) to flying electric model airplanes:

Practice has shown that a good “rule of thumb” exists for determining the power requirements for many types of common R/C aircraft. We can determine the minimum input power (Watts) needed per pound of aircraft necessary to fly a specific type of aircraft in a specific style. Generally, electric modellers have found that the following information to be reliable (all for outdoor models unless specified):

- High-wing, slow flying, indoor-type model airplane can fly with less than 50 Watts per pound
- High-wing, trainer-type models, capable of taking off from grass and flying in circles, require 50 to 60 Watts per pound
- Low-wing aerobatic indoor-type models require 80 to 120 Watts per pound
- Sport planes, capable of mild aerobatics and somewhat fast and aggressive flying require 80 to 100 Watts per pound
- Fast-flying scale-type models, or large pattern competition models, capable of aerobatic manoeuvres require 100 to 150 Watts per pound
- Extreme 3-D (hovering, vertical climbing, etc.) models require 150 to 200 Watts per pound, or more!

Wing Loading:

Of course, other factors affect these examples. Wing loading, or the weight of the airplane divided by its wing area, affect flight performance. Generally, a lower wing loading will allow a plane to maintain level flight with fewer input Watts; a higher wing loading will need more power. Other factors affecting needed power are other aerodynamic characteristics (airfoil, etc), parasitic drag (the efficiency of the airframe), temperature and altitude (air-density where you are flying), etc.

As well, while a very low wing loading is ideal for slow flying models, it is not usually suitable for flying in windy conditions. Conversely, a high wing-loaded model will fly faster and will need more space in which to fly and manoeuvre.

Generally, the following indicates what wing loading ranges are suitable for specific styles of flying:

- under 4 ounces per square foot: indoor flying and flying in 2 mph winds or less
- 5 to 15 ounces per square foot: outdoor slow-flying in somewhat mild conditions, or endurance-type aircraft such as sailplanes, SAM aircraft, etc.
- 16 to 24 ounces per square foot: outdoor flying in reasonably windy conditions, with reasonably faster speeds
- 25 ounces per square foot and higher: outdoor flying of faster scale and some competition models, capable of flying in moderately windy conditions; requires substantial landing area.

Length of flight:

Understanding the relationship between power consumption and battery capacity can also help us in estimating the flight or motor-run time, based on given information

A specific battery pack can deliver a certain quantity of power at up to a maximum level of current and for a specific amount of time.

Example: A 2000mAh battery pack can deliver 2000 milliamps (or 2 Amps) of current for an hour at a current-draw rate of 2 Amps (1C), but is rated for as high as 40Amps current in continuous use (20C).

If the battery were to be used at 40 Amps (20C) for a full flight, theoretically, the battery would be drained at a rate of 20 times faster than 2 Amp (or 2000mAh) for an hour, then the battery would last for 1/20th of one hour, or 3 minutes.

If the battery were drained at a constant rate of 30 Amps (15C), then the 2000mah battery would last for 1/15th of one hour, or 3 minutes.

If the battery were drained at a constant rate of 20 Amps (10C), then the 2000mAh battery would last for 1/10th of one hour, 6 minutes.

Of course, batteries aren't fully drained under normal use, and we rarely discharge them at a constant rate, so these figures can vary somewhat. However, you can get a rough estimate of how much flying time you can get from a battery if you can come up with an estimate of your average current draw during a flight.

1) Take the rated capacity "C" of the battery pack (in mAh) and convert it to Amp-minutes (Am)
eg. C = 2,000 mAh = 2.0 Ah x 60 = 120 Am

2) Divide the capacity in Amp-minutes by the estimated average current draw

eg. Max current draw may be 35A but at half-throttle it may be about 20A and most of the flight is expected to be at half throttle. An estimate of average current may be about 25 A.

120 Amp-minutes divided by 25Amps yields an estimated motor run time of about 4.8 minutes.

.....
Tip of the Month

You go to use a glue applicator and you discover that, after sitting for several weeks unused, the nozzle is completely clogged. Has this happened to you?

Well there is an easy and inexpensive way to prevent all of your glue applicator bottle nozzles from ever clogging again. Just pinch a little clump of modelling clay ("Plasticine") over the nozzle opening in between uses. The modelling clay make a more effective seal than the average push-on cap, and keeps the glue fluid for months

And do you want to prevent your CA from hardening up over time in its bottle? Store the bottle in a pickle jar full of a granular dessicant (silica gel or similar). CA reacts to moisture, so in a very dry dessicant atmosphere, CA will stay liquid for a long time.

Fly with a Buddy

Here is the contact list for the COGG club's current (2008) membership. If there are any errors in the data, please contact me at 416-493-0111 or rsbourke@3web.com for corrections.

Joseph Baltaza	19 Gaitwin St.	Brantford	N3P 1A9	519-751-3698
Jozef Banial	5248 Alicante St.	Mississauga	L5V 1S9	905-567-3925
Helmut Berger	9 Michael Drive	North York	M2H 2A2	416-493-4237
Bryan Booth	1 Hamilton Hall Drive	Markham	L3P 2P1	905-294-6472
Tony Boothman	239 Dodson Rd.	Barrie	L4N 4N9	705-722-8630
Roy Bourke	56 Clareville Crescent	North York	M2J 2C1	416-493-0111
Gerhard Bruckner	3303 Don Mills Rd. Apt 803	North York	M2J 4T6	416-496-1073
Rodney Clark	71 Redwater Drive	Etobicoke	M9W 1Z5	416-749-0610
Steven Cole	54 Iona Ave.	Toronto	M4C 5J4	416-691-9547
Greg Galler	49 Daniele Ave. North	Beeton	L0G 1A0	905-729-3240
Bernard Gillespie	33 York Downs Drive	Toronto	M3H 1H7	416-636-6949
Bill Gillespie	205 - 172 Eighth Street	Collingwood	L9Y 4T2	705-445-8592
Bill Gillies	29 Irwin Drive	Whitby	L1N 9B8	905-666-9707
Ralph Godin	899 Clifton Blvd.	Innisfil	L9S 4L7	705-431-6502
Jack Humphreys	2830 Midland Ave Unit #3	Scarborough	L3R ZE4	416-291-5809
Ronald Khoo	31 Formosa Drive	Richmond Hill	L4S 1S6	905-780-8213
Ernst Lumesberger	129 Kerr Blvd	Alliston	L9R 1C7	705-435-7984
Edmund Martinowski	243 Pine Drive	Barrie	L4N 4H6	705-721-0773
Des McKee	66 Teresa Drive	Whitby	L1N 6J2	905-668-0735
John McMillan	80 Ravine Park Cresc	Scarborough	M1C 2M6	416-284-5466
Doug Pike	3 Treleaven Drive	Brampton	L6Y 1X5	905-451-0791
Joseph Plucinsky	41 Cleavholm Drive	Georgetown	L7G 3E3	905-877-2702
Imre Rozsa	300 Antibes Drive Apt. 1910	North York	M2R 3N8	416-514-1535
Stanley Shaw	39 - 383 Edinburgh Road S.	Guelph	N1G 2K7	519-763-7111
Bob Sherliker	2496 Folkway Drive	Mississauga	L5L 2J6	905-820-2799
Mike Thomas	61 Alhart Drive	Etobicoke	M9V 2N1	416-748-2833
Neil Tinker	35 Cairnside Crescent	North York	M2J 3M9	416-491-5822

.....
CENTRAL ONTARIO GLIDER GROUP (COGG) **APPLICATION FOR 2008 MEMBERSHIP**

Name (Please print) _____

Address _____ City _____

Province/State _____ Postal/Zip _____ Telephone _____

E-Mail _____ MAAC No. _____ LSF No. _____ Level _____

Transmitter frequencies used: Please send my Gull newsletters by Canada Post
 1) _____ 2) _____ 3) _____ 4) _____ E-mail:

Full Membership	\$25.00	<input type="checkbox"/>	Please send completed form and payment to: Tony Boothman 239 Dodson Road Barrie, ON, L4N 4N5
Senior (65 and over)	\$20.00	<input type="checkbox"/>	
Junior (under 18)	First year free	<input type="checkbox"/>	
(second year under 18)	\$10.00	<input type="checkbox"/>	

Amount enclosed _____
 Cheque Money Order Other (Please do not send cash by mail)

I will abide by the bylaws of COGG, and fly my models in accordance with the M.A.A.C. Safety Code:

Signature _____ Date _____



Roy Bourke's EPP Eagle, ready to soar over the COGG Field this summer